

# Make It Work

## Hunting Ground Faults



***The Fire Alarm Technician's  
Essential Guide to Understanding  
the Elusive Ground Fault***

**Douglas Krantz E. T.**

OK, this excerpt is from the chapter “**Troubleshooting – Look at What the Panel is Looking At**”, (highlighted in yellow). Order the rest of the book from:

<https://douglas-krantz-s-fire-and-life-safety.myshopify.com/products/make-it-work-hunting-ground-faults-mobile-version>

## Chapter Headings:

- What Causes a Ground Fault
- When to Fix a Ground Fault
- Fire Alarm System Ground Fault Detector
- Danger - Ground Fault
- Troubleshooting the Ground Fault While Not Using the Ground Fault Light
- **Troubleshooting – Look at What the Panel is Looking At**
- Categorizing Ground Faults
- Soft Ground Fault
- Induced (Ghost) Ground Fault
- Many Types of Induced Ground Faults

# Copyright 2019 by Douglas Krantz

All Rights Reserved. No part of this book may be reproduced in any form or by any electronic or mechanical means including storage and retrieval systems without written permission from the author.

Douglas Krantz’s Technician’s Corner  
6520 Irving Ave So  
Richfield, MN 55423

# Troubleshooting – Look at What the Panel is Looking At

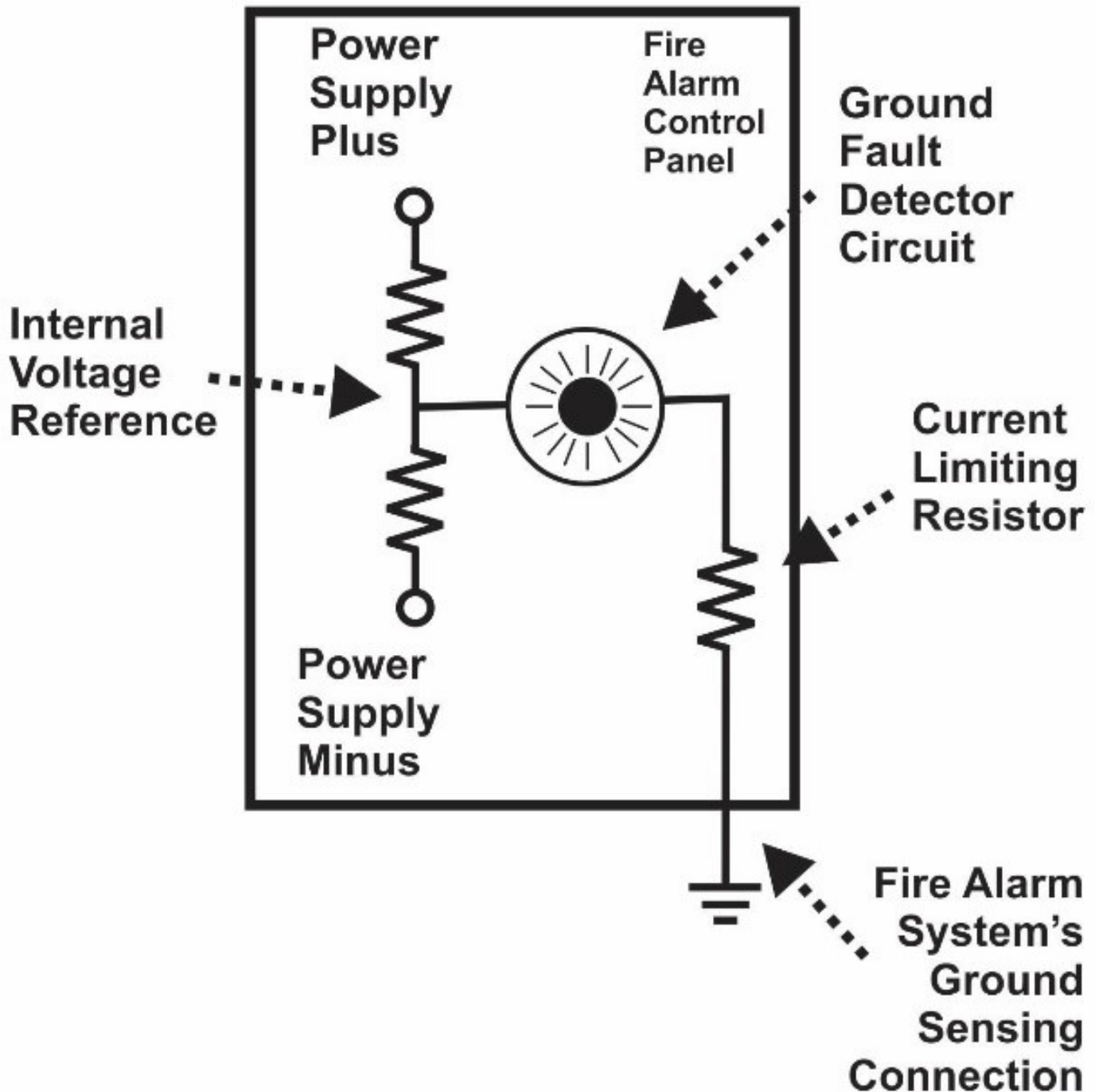

Almost always, the ground fault is not in the panel; almost always the ground fault is someplace else besides the panel.

As such, the panel cannot say anything more about the ground fault than “The ground fault exists.”

Because the panel can’t say anything more than “There’s a Ground Fault,” when troubleshooting, look at what the panel is looking at, don’t look at the panel.

## **How the Panel Detects a Ground Fault**

Every model of panel has its own method of measuring to see if there’s a ground fault. Some will measure the current flowing to or from the Fire Alarm System’s Ground Sensing Connection, some will measure the voltage at the Ground Sensing Connection and compare that to the Internal Reference Voltage.

All of the Fire Alarm Control Panels, though, are actually looking to make sure that the voltage at the Fire Alarm

System’s Ground Sensing Connection is the same voltage as the Internal Reference Voltage.

## **Imprecise Electronics**

Electronics are never precise; there’s always a little slop in the system. The most precise specifications for electronics will always show a + or – amount. From one standpoint, that means that even the most precise specification is not precise.

In a building-wide fire alarm system, ground fault current may be too little to measure, but there’s always a little electrical leakage. In the fire panel’s maintenance book, there is a section showing the specifications. One of the specifications is the current or resistance that triggers the ground fault circuitry. A technician probably won’t need to use that specification very often, but it’s a good idea to know that it’s there.

**I highly recommend that technicians who are serious about troubleshooting study the specifications for the panels they are working with. When a technician doesn't know the specifications, troubleshooting is like trying to assemble a pocket watch while blindfolded.**

## Finding the Reference Voltage

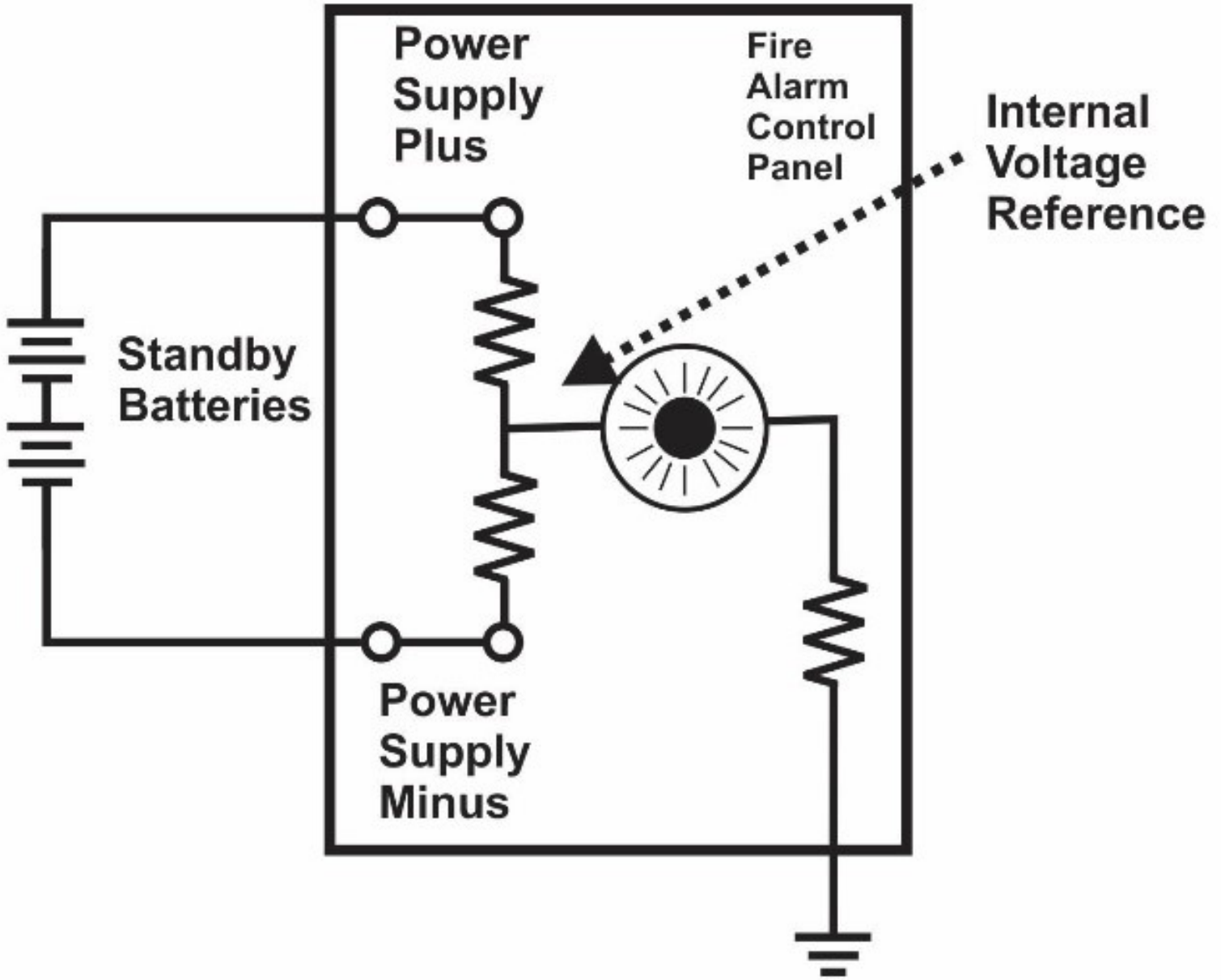



The fire alarm control panel has an Internal Voltage Reference Point. For the technician, though, finding that point on the printed circuit board is impossible. There's no test point to connect the voltmeter to, and there's no documentation to tell the technician where to find this reference point.

A technician can, however, find out what the panel is seeing for building ground.

### **Call Technical Support**

Usually, calling tech support can get the technician information on where to connect the voltmeter and what voltage should be there. If technical support can't give the information, the technician has to determine the voltage, sort of. It's a kind of guess-and-verify situation.

### **Figure It Out Yourself**

The technician has to be familiar with how to find the reference voltage.

## [Get the Book “Make It Work – Hunting Ground Faults”](#)

The reference voltage is a comparison voltage; it's the voltage measured from the positive battery terminal as it is compared to building ground, and it's a second voltage measured from the negative battery terminal as it is compared to building ground. Measuring this voltage can tell the technician a great deal about whether there is a ground fault in the first place, and it also shows other information about the ground fault.

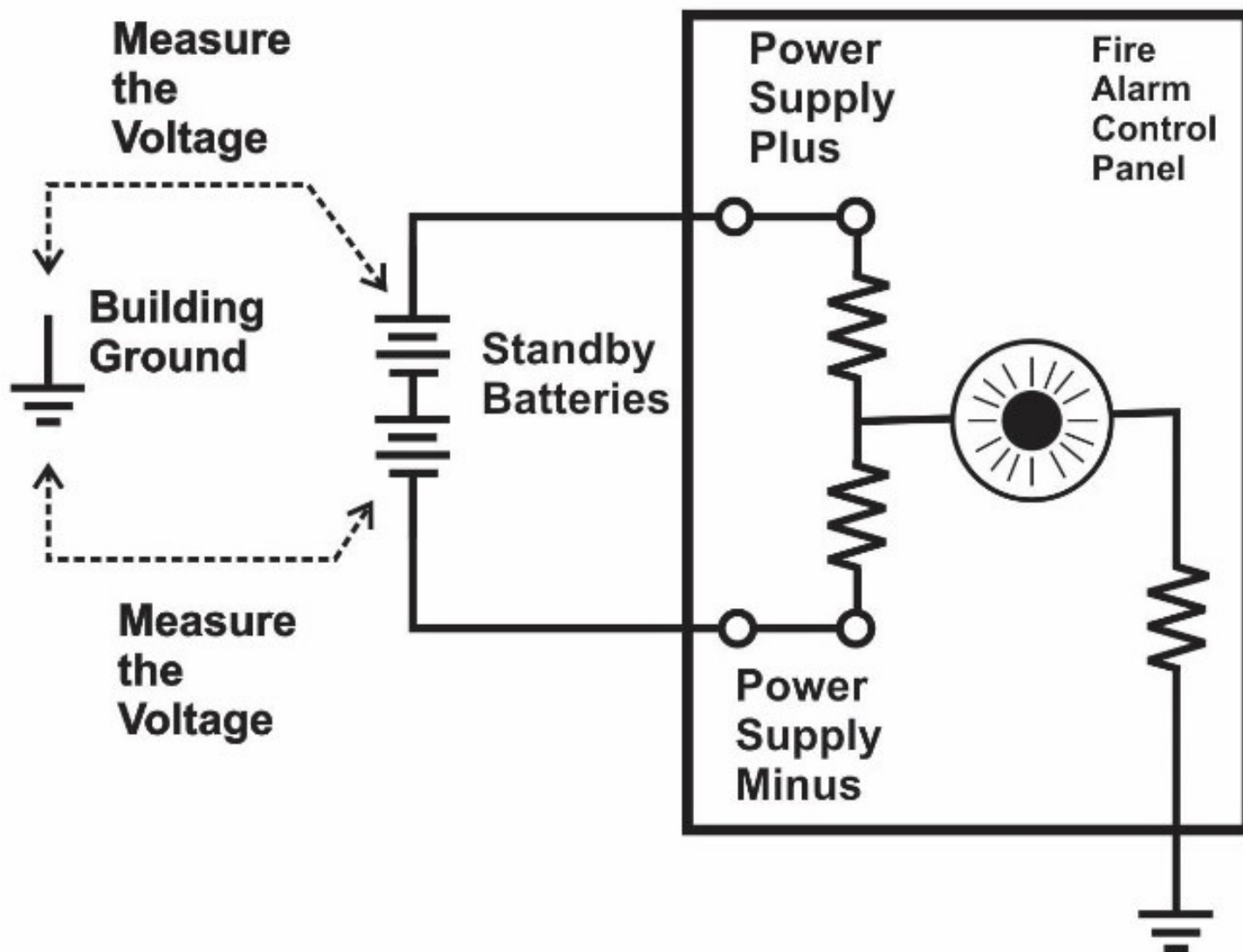

These plus and minus terminals of the batteries can be considered the same electronic points as the positive and negative power supply on the printed circuit board.

## Troubleshooting Trick

When you don't know the normal ground reference voltage of the panel – turn your thinking around.

Instead trying to figure out what voltage is normal for the panel, assume that what you read is either normal, or shows ground fault. Then, when disconnecting loops to find out which loop has a ground fault, only look for a change in this voltage. If the voltage changes, you're connecting or disconnecting the ground fault. It's a troubleshooting start.

### ***Exact Reference Voltage Isn't Important***

When measuring them, the exact voltage seen on the batteries isn't the important part. It's the compared voltage ratio measured between each battery terminal and building ground that's important.

**24  
Volts** **≠** **24  
Volts**

Remember that the battery voltage should be 12 or 24 Volts Nominal (12 Volts or 24 Volts are

the names of the batteries, not their voltages).

A 12 Volt battery can measure anywhere from 10 to 13.75 Volts, and a 24 Volt Battery can measure anywhere from 20 to 27.5 Volts. That’s not a precise 12 volts or 24 volts, so the measurements are not going to be precise.

## **Compare Voltages**

When comparing the battery terminal voltages to ground, if the voltages on the plus or minus side of the batteries are approximately the same, chances are good there’s really no ground fault. When comparing the battery terminal voltages to ground, if the voltages on the plus or minus side of the batteries are vastly different, chances are good there’s a ground fault somewhere.

## **Exception**

Don't count on the measurements to always be proof of ground fault, become familiar with the voltage measurements on the model of panel being worked on.

I have found (and confirmed with the manufacturer's technical support) that on one panel, the voltage measured to the negative terminal of the battery compared to building ground is supposed to be about 1.2 volts.

That 1.2 volts is what I measured when there was no ground fault on the system. When the intermittent ground fault returned, the voltage went to about 0.8 volts.

If something looks different from what you think it should be, do as I did and call technical support. Technical support is there to help.

Bottom line though for long term troubleshooting, get used to reading the battery-voltage-to-ground

measurements for each make and model of fire alarm panel you’re working on. The measured voltages are different for each make and model, but learning to make these measurements is a good start to becoming an expert ground fault fixer.

## Floating Ground Voltage

For ground fault detection, most panels are continuously connected to building ground. However, a few fire alarm panels actually connect to ground for a short time once every minute or so. For that kind of panel, most of the

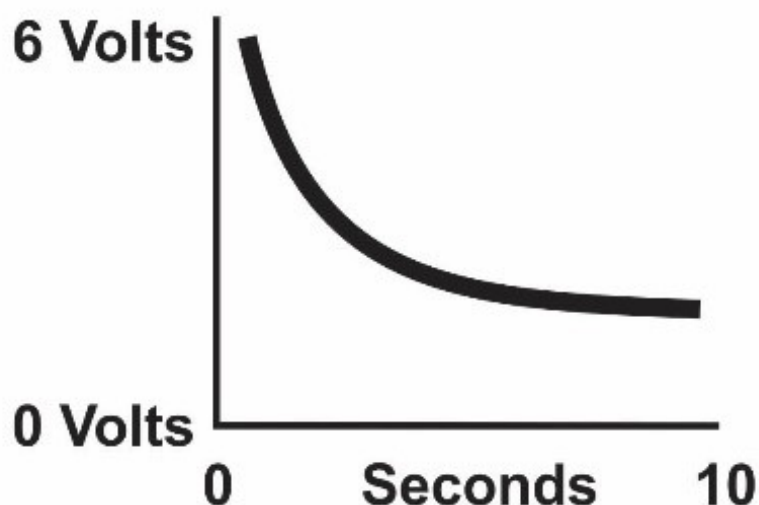

time, the whole fire alarm system isn’t connected to building ground at all.

Because the panel isn’t connected, using a voltmeter makes the voltmeter the only electrical pathway. The

voltmeter conducts current to ground from the long, thin capacitor called a fire alarm loop.

Any residual voltage between the fire alarm system and building ground is going to discharge through the voltmeter.

The voltage shown on a voltmeter is really a measurement of the current through the meter times the fixed resistance of the meter. The result is shown as a voltage. (This is Ohm’s Law.) Once the voltmeter discharges the residual voltage, there will be a very small current, which is a low voltage reading, often less than 1.0 volts.

When trying to measure the voltage from the plus or minus battery terminals to building ground, these will be weird readings on the voltmeter.

### ***The Weird Readings are Normal***

**On a “floating” fire alarm panel, when trying to measure the voltage to ground on both the plus and the minus side of the batteries, the voltage**



[Get the Book “Make It Work – Hunting Ground Faults”](#)

**will start out lower than expected, and drift down even lower over the next few seconds.**

**This isn't something wrong with how you're measuring the voltage, this isn't something wrong with your voltmeter, this isn't something wrong with the fire alarm system or the fire alarm panel.**

**When there isn't a ground fault in a floating voltage fire alarm system, this is normal and expected.**

A weird reading is good.

When there's a ground fault, the ground fault will discharge the voltage before a measurement can be taken so the voltage readings will be closer to a normal panel's the ground faulted measurements; the measured voltage will be close to zero on one side of the batteries and close to full battery voltage on the other side of the batteries.

Get used to which panels “float”.

## ***Most Reliable Method of Confirming the Ground Fault***

Measuring battery-voltage-to-building-ground is the most reliable method of determining if there truly is a ground fault. A few times these measurements won't work. Most of the time, though, this kind of measurement will show whether or not there is a ground fault – and that's much better than trying to watch the ground fault light.

[Make It Work – Hunting Ground Faults](#)